

NAIS

FOR PC BOARD
TO FLAT CABLE

PCB TYPE CONNECTORS (AXP)

Low profile
5.7mm



Mini-dip type

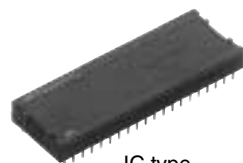

IC type

FEATURES

1. High density mounting can be done.

Because of its 5.7mm high and low profile, its effectiveness for PC board mounting is broad.

2. Labor saving in making connections is achieved.

All terminals can be connected as a group in this pressure connection

construction, and by means of the temporary cover stop, cable insertion is easily carried out, and connection labor is minimized.



PRODUCT TYPES

No. of contacts	Mini-Dip type		IC type (Reverse terminal layout)
	Standard terminal layout	Reverse terminal layout	
10	AXP410218	AXP410618	—
14	AXP414218	AXP414618	AXP514618
16	AXP416218	AXP416618	AXP516618
20	AXP420218	AXP420618	AXP620618
24	—	—	AXP524618
26	AXP426218	AXP426618	—
30	AXP430218	AXP430618	—
34	AXP434218	AXP434618	—
40	AXP440218	AXP440618	AXP540618
50	AXP450218	AXP450618	—
60	AXP460218	AXP460618	—
64	—	AXP464618	—

Notes) 1. Tray packaging: Outer carton 200 pcs.

2. The upper surface of a connector with mini dip type standard pin layout is marked with “▼AXP4VV2”. Connectors with reverse pin layout is marked with “▲AXP4VV”.

The orientation of the triangle distinguishes standard from reverse pin layouts.

3. The IC type PCB type connectors are reverse terminal layout only.

4. For available foreign standard products, refer to “STANDARDS CHART” on the end of the catalog.

SPECIFICATIONS

1. Characteristics

	Item	Specifications	Conditions
Electrical characteristics	Rated current	1A	
	Breakdown voltage	650V AC for 1 min.	Detection current: 1mA
	Insulation resistance	Min. 1,000MΩ	at 500V DC megger
	Contact resistance	Max. 15mΩ	Measured based on the HP4338B measurement method of JIS C 5402
Environmental characteristics	Ambient temperature	−55°C to +105°C	
	Vibration resistance	10 to 55Hz at the double amplitude of 1.52mm	No opening more than 1μsec. at Max. 100mA carrying current
	Shock resistance	490m/s ² {50G}	

2. Material and surface treatment

Part name	Materials	Surface treatment
Molded portion	Glass reinforced PBT (UL94V-0)	—
Contact	Copper alloy	Au plating over Ni

3. Applicable cable

Flat cable (stranded wire)	Pitch 1.27mm/conductor, AWG28 (7 conductors/0.127 dia.)
----------------------------	---

DIMENSIONS

• Mini-dip type



Dimension table (mm)

No. of contacts	A	B	C
10	17.5	10.16	10.3
14	22.7	15.24	15.5
16	25.1	17.78	17.9
20	30.2	22.86	23.0
26	37.9	30.48	30.6
30	42.9	35.56	35.7
34	48.0	40.64	40.8
40	55.6	48.26	48.4
50	68.3	60.96	61.1
60	81.0	73.66	73.8
64	86.1	78.74	78.9

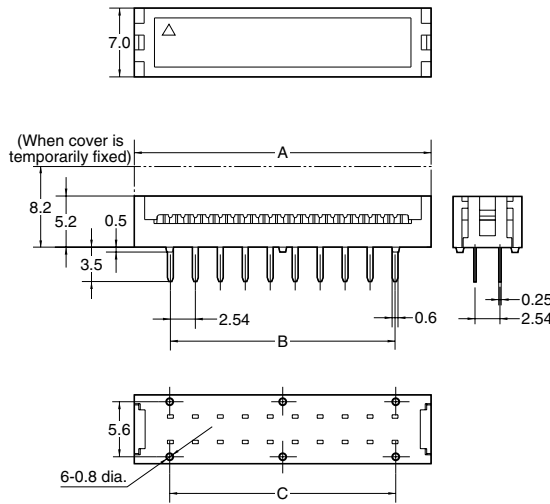

Recommended PC board pattern (BOTTOM VIEW)

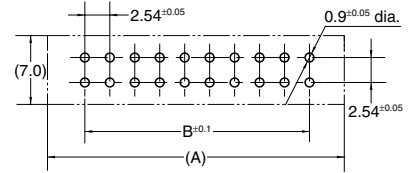

• IC type



Dimension table (mm)

No. of contacts	A	B	C	D	E
14	20.0	15.24	13.0	7.62	10.6
16	22.5	17.78	15.0	7.62	10.6
20	27.6	22.86	20.0	7.62	10.6
24	32.7	27.94	25.0	15.24	18.2
40	53.0	48.26	45.2	15.24	18.2

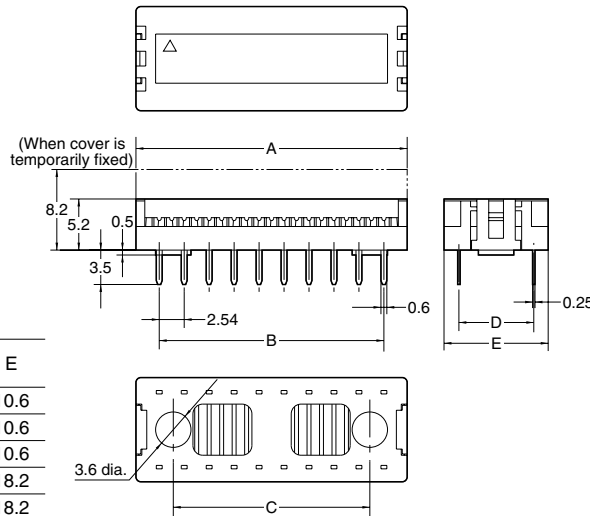

Recommended PC board pattern (BOTTOM VIEW)

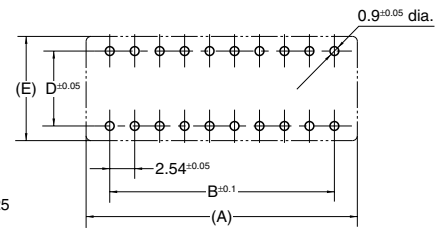

CABLE NO. AND TERMINAL POSITION CORRELATION DRAWING

Terminal layout

Terminal numbers are not indicated on the connector. When the cable numbers are temporarily assigned from the end as 1, 2, 3, 4....., the corresponding terminals are as shown in the drawing below.

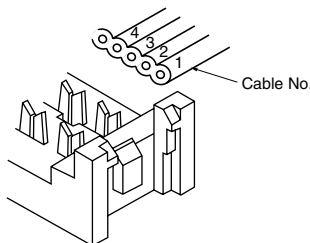

Cable No. layout (Top view)

Standard terminal layout Reverse terminal layout

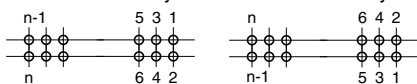

NOTES

1. Regarding design of PC board

The connector terminal numbers are not indicated. Using the triangle mark on the cover as reference, the PC board design and the cable connections can be carried out.

2. Regarding the soldering operation

Soldering should be carried out under the conditions given below.

260°C: Within 10 seconds

300°C: Within 5 seconds

350°C: Within 3 seconds

3. Regarding external force applied to the cable

Because no strain relief is provided for the PC board type connector, care should be taken not to apply external force to the cable. Sufficient slack should be provided in the cable length.

4. Regarding handling of terminals

Care should be taken with the terminals because repeated bending of the terminals can lead to damage.

5. Regarding handling of the cover

After the cover has been inserted into the base, when it is to be removed, care should be taken not to apply excessive force to displace the radius section of the cover since that will cause damage.

6. Regarding the cable pressure connection tool

The special tool provided for cutting the cable and making the pressure connections should be used.